

18 | H20 Incremental Optical Encoder



The H20 is an all metal, extremely rugged encoder designed to economically fill the resolution range up to 2048 cycles per turn. This compact unit features a shock resistant disc, heavy duty bearings, and EMI shielding. The H20 conforms to NEMA 4 and 13 requirements. The H20 is also available in a hub shaft style with a flexmount (inset) for easy mounting directly to small motors. Typical applications of the H20 include machine control, process control, agricultural machinery, textile equipment, robotics, food processing, and metering.



H20 Incremental Ordering Options FOR ASSISTANCE CALL 800-350-2727

Use this diagram, working from left to right to construct your model number (example: H20DB-37-SS-500-ABZC-7272-SM18-24V). All notes and tables referred to can be found on pages 50-51.

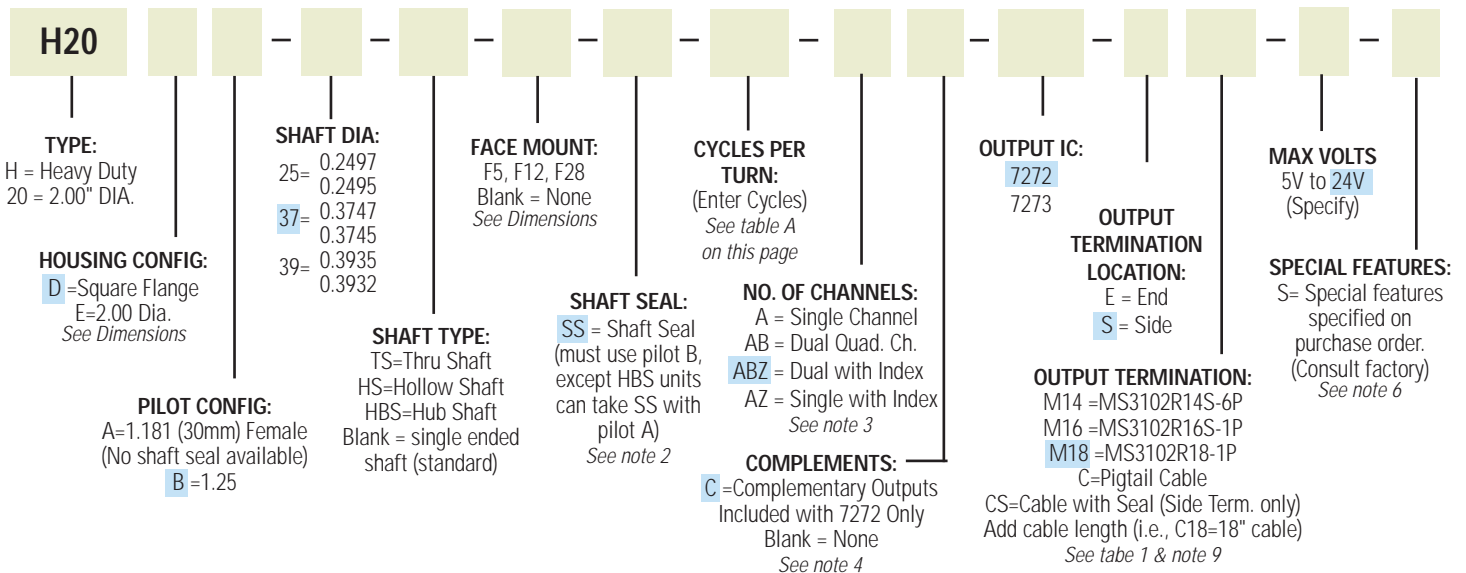

EXPRESS ENCODERS® Items highlighted with are standard Express Encoders and ship in one to three days.

T2 option is available as a standard H20 Express Encoder. See page 32-33.

Table A H20 Disc Resolutions

1* 2 3 5 **6** 8 10 11 12 24 25 30 32 40 50 60 64 **70** 75 80 100 105 **112** 115 120 125 150 192 200 240 250 256
300 336 360 400 410 500 510 512 600 720 785 1000 1024 Resolutions Shown in **RED** are not available as Express Encoders

* No index. For interpolation please specify the multiplied output (up to 2,048 for H20) in the model number, i.e. 2,048-T2.

Housing Type

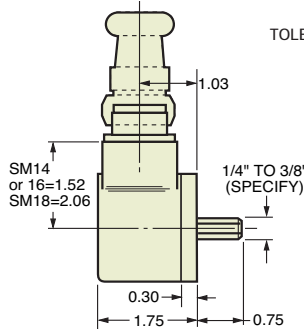
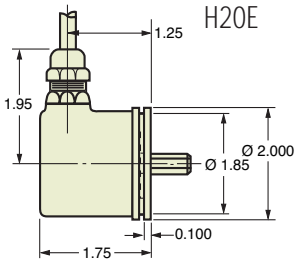

TOLERANCES: .XX=±0.01, .XXX=±0.005

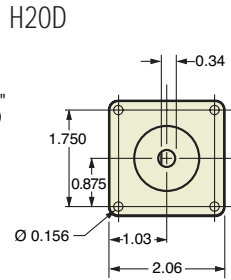

Optional Face Mounts

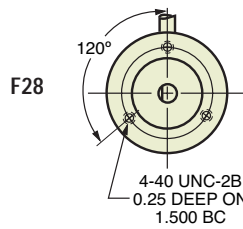
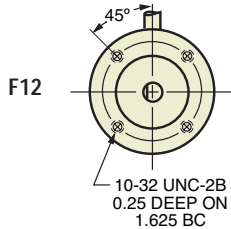
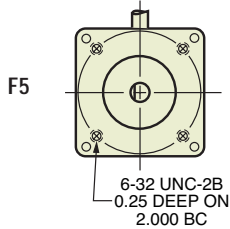

SPECIAL SHAFT OPTIONS

Hollow Shaft

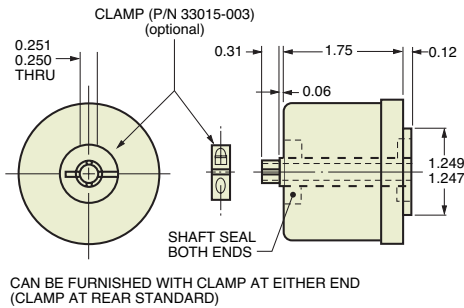

Hub Shaft

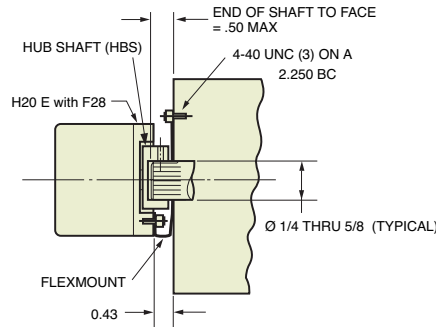

Thru-Shaft

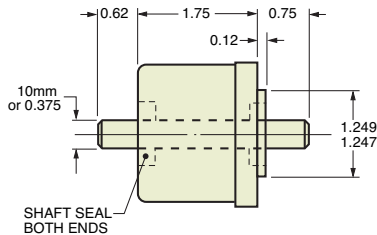

Pilot Options

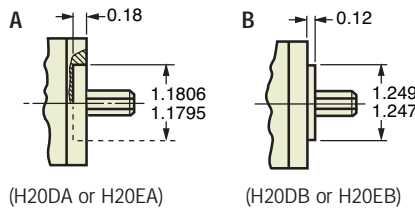
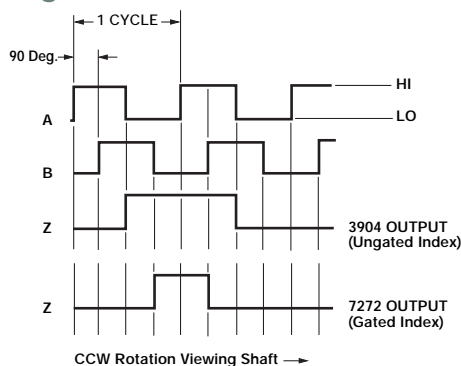
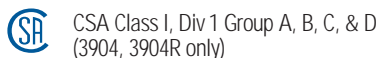
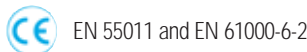

Figure 1 Output Waveform



Certifications

The H20 Incremental Encoder is available with the following certifications:



See Regulatory Information on pages 47-49 for further certification details.

Mechanical Specifications

Shaft Diameter: 1/4" thru 3/8" and metric versions. Hollow shaft, hub shaft or thru-shaft versions available.

Flat On Shaft: 0.75 x 0.03 deep

Shaft Loading: up to 40 lbs. axial and 40 lbs. radial

Shaft Runout: .001 T.I.R. maximum

Starting Torque at 25°C: 1.0 in-oz maximum without shaft seal; 2.5 in-oz maximum with shaft seal; 4.0 in-oz thru-shaft

Bearings: 52100 bearing steel

Shaft material: 303 stainless steel

Bearing Housing: Die cast aluminum with iridite finish

Cover: Die cast aluminum with iridite finish (For MS or CS terminations), otherwise drawn aluminum with iridite finish

Bearing Life: 1.5×10^9 revs at rated load (10,000 hrs at 2500 RPM)

Maximum RPM: 8,000 (see Frequency Response)

Moment of Inertia: 2.0×10^{-4} oz-in-sec²

Weight: 9 oz. typical

Electrical Specifications

Code: Incremental

Output Format: 2 channels in quadrature, 1/2 cycle index gated with negative B channel as standard. Ungated index when 3904 is specified as the output device

Cycles per Shaft Turn: 1 to 2048 (see table A page 18) For resolutions above 1024 see interpolation options on pages 31 and 32)

Supply Voltage: 5 to 24 VDC available

Current Requirements: 100 mA typical + output load, 250 mA (max)

Output Device: (see note 5)

7272: Line Driver, 5 – 28 VDC, $V_{out} = V_{in}$

7272: Line Driver, 5 – 28 VDC, $V_{out} = 5$ VDC (special feature)

7273: Open Collector, accepts 5 – 28 VDC

Protection Level: reverse, overvoltage and output short circuit (see note 5)

Frequency Response: 100 KHz (up to 1024 cpt; 250 KHz with T2 options (see note 7)

Output Terminations: See Table 1, page 51

Note: Consult factory for other electrical options

Environmental Specifications

Enclosure Rating: NEMA 4 & 13 (IP66) when ordered with shaft seal (on units with an MS connector) and a cable gland (on units with cable termination)

Temperature: Operating, 0° to 70°C; extended temperature testing available (see note 8); Storage, -25° to 90°C unless extended temperature option called out

Shock: 50 g's for 11 msec duration

Vibration: 5 to 2000 Hz @ 20 g's

Humidity: 98% RH without condensation

NOTES & TABLES: All notes and tables referred to in the text can be found on pages 50 and 51.

1. Mounting is usually done either using the D-style square flange mount, E- or G-style servo mounts, or one of the standard face mounts, F1 for example. Consult factory for additional face mount options.
2. The shaft seal is recommended in virtually all installations. The most common exceptions are applications requiring a very low starting torque or those requiring operation at both high temperature and high speed.
3. Non-standard index widths and multiple indices are available by special order. Consult factory.
4. Complementary outputs are recommended for use with line driver type (source/sink) outputs. When used with differential receivers, this combination provides a high degree of noise immunity.

5. Output ICs

Output IC's are available in either Line Driver (LD) or Open Collector (OC) types. Open Collectors require pull-up resistors and so have higher output impedance. In general it is recommended to use a Line Driver style of output. They can either source or sink current and their lower impedance mean better noise immunity and faster switching times. Our applications specialists would be pleased to discuss your system requirements and the compatibility of your receiving electronics with Line Driver type outputs.

7272

Multi-voltage Line Driver: 100 mA source/sink. Input voltage 5 to 28 VDC standard (Note: $V_{out} = V_{in}$). Available with voltage regulator for 5 to 28 VDC input/TTL output (called out as a special feature)*. This driver is TTL compatible when used with 5 volt supply or with a voltage regulator option. Supply lines are protected against overvoltage to 60 volts and reverse voltage. Outputs are short circuit protected for one minute. Supply current is 120 mA typical (plus load current). This is the recommended replacement for 3904R and 7406R open collector outputs with internal pullup resistors. This is also a direct replacement for any 4469, 88C30, 8830 or 26LS31 line driver

4469

Multi-voltage Line Driver: 100 mA source/sink. Input voltage 5 to 15 VDC standard (Note: $V_{out} = V_{in}$). Available with voltage regulator for 5 to 28 VDC input/5V output (called out as a special feature)*. TTL compatible when used with 5 volt supply or with voltage regulator. Supply lines are protected against overvoltage to 60 volts and reverse voltage. Outputs are short circuit protected for one minute. Supply current is 90 mA typical (plus load current). This is the replacement for 3904R and 7406R outputs for systems operating at 15 volts and below. This is also a direct replacement for any 88C30, 8830, or 26LS31 Line Driver.

* Regulated Output Option:
Limit signal output current to 50 mA per channel on Supply voltages above 15 VDC.
Operation above the stated levels may result in thermal shutdown of the regulator.

7273

Open Collector: Current sink of 80 mA max. Current sourced by external pull-up resistor. Output can be pulled up to voltage other than supply voltage (30 V max). Input voltage 5 to 28 VDC standard. Supply current is 120 mA typical. This replaces prior IC's with designations of 3904, 7406, 3302, 681 and 689.

7406 (R)

Open Collector: Current sink of 40 mA max. Current sourced by external pull-up resistor. When called out as 7406R, pull-ups are internal and sized at approximately 100 ohms/volt and current sink is limited to 30 mA. Output can be pulled up to voltage other than supply voltage (30 V max) when the 7406 is used without internal pull-ups. Voltage regulator can be used to allow supply voltage up to 28 V (called out as a special feature). Supply current is 100 mA typical, 120 mA with internal pull-ups. The 7406R is replaced by the 4469 or the 7272 in system upgrades, or with the 7273 if external pull-ups are used.

3904 (R)

Open Collector: Current sink of 80 mA max. Current sourced by external pull-up resistor. When called out as 3904R, pull-ups are internal and sized at approximately 100 ohms/volt and current sink is limited to 70 mA. Output can be pulled up to voltage other than supply voltage (30 V max) when the 3904 is used without internal pull-ups. Supply Current is 80 mA typical, 100 mA with internal pull-ups. The 3904R is replaced by the 4469 or the 7272 in system upgrades, or with the 7273 if external pull-ups are used.

6. Special -S at the end of the model number is used to define a variety of non-standard features such as special shaft lengths, voltage options, or special testing. Please consult the factory to discuss your special requirements.
- 7 Higher frequency response may be available. Please consult with the factory.
8. Extended temperature ratings are available in the following ranges: -40 to 70°C, -40 to 85°C, -20 to 105°C and -40 to 105°C depending on the particular model. Extended temperature ranges can affect other performance factors. Consult with factory for more specific information.
- 9 Mating straight plug receptacles may be ordered from the factory:

For M12 use MS3116F12-10S

For M14 use MS3106F14S-6S

For M14/19 use MS3116F14-19S

For M16 use MS3106F16S-1S

For M18 use MS3106F18-1S

For M20 use MS3106F20-29S

For additional Accessories refer to page 46.

For standard pinouts, refer to the facing page.

Table 1: Incremental Output Terminations

The connector style will determine pinouts. For example, an encoder with ABC channels and an M18 connector uses the table to the right.

M14 CONNECTOR	M16 CONNECTOR	CHANNELS DESIGNATED IN MODEL NO.	
PIN	PIN	ABZ	ABC
E	A	A	A
D	B	B	\overline{B}
C	C	Z	\overline{A}
B	D	+V (SUPPLY VOLTAGE)	
F	E	—	\overline{B}
A	F	0 V (CIRCUIT GROUND)	
	G	CASE GROUND (CG) (except H20)	

M18 CONNECTOR	
PIN	CHANNEL
A	A
B	B
C	Z
D	+V
E	—
F	0V
G	CG
H	\overline{A}
I	\overline{B}
J	\overline{Z}

WIRE COLOR (22AWG)	DA 15P CONNECTOR	CHANNELS DESIGNATED IN MODEL NO.		
		ABZ	ABC	ABZC
YEL	13	A	A	A
BLUE	14	B	B	B
ORN	15	Z	—	Z
W-Yel	10	—	\overline{A}	\overline{A}
W-Blu	11	—	\overline{B}	\overline{B}
W-Orn	12	—	—	\overline{Z}
RED	6	+V (SUPPLY VOLTAGE)		
BLK	1	0 V (CIRCUIT GROUND)		
GRN	9	CASE GROUND (CG) (except H20)		
WHITE		SHIELD DRAIN (Shielded Cable Only)		

M12 CONNECTOR	
PIN	CHANNEL
A	A
B	B
C	Z
D	+V
E	—
F	0V
G	CG
H	\overline{A}
J	\overline{B}
K	\overline{Z}

Table 2: Disc Resolutions for Incremental Encoder Models H25, H38, H40, L 25, E25

Resolutions highlighted with are available as standard **Model H25 EXPRESS ENCODERS**[®] that ship in one to three days.

1, 2, 3, 5, 6, 7, 8, 10, 13, 16, 20, 24, 25, 26, 30, 32, 33, 34, 36, 37, 40, 45, 48, 50, 51, 56*, 60, 64, 66, 72, 75, 80, 86, 88, 90, 100, 102, 120, 122, 125, 127, 128, 132, 144, 148, 150, 158, 160, 175, 176, 180, 187, 192, 200, 202, 204*, 217, 220, 240, 250, 254, 255, 256, 264*, 274, 280, 283, 288, 292, 300, 312, 320, 321, 325, 360, 366, 372, 375, 377, 380, 381, 384, 385, 393, 400, 430, 432, 450, 462, 480, 490, 500, 502, 508, 512, 522, 530, 550, 560*, 576, 598, 600, 604, 625, 628, 635, 638, 640, 660, 672, 676, 680, 687, 690, 700, 720, 725, 735, 740, 744, 748, 750, 762, 768, 780, 785, 800, 812, 825, 850, 864, 878, 888, 900, 912, 914, 938, 942, 955, 960, 1000, 1016, 1024, 1030, 1035, 1036, 1040, 1054, 1056, 1074, 1076, 1080, 1088, 1100, 1101, 1125, 1136, 1200, 1237, 1250, 1257, 1270, 1280, 1300, 1314, 1332, 1333, 1390, 1400, 1414, 1427, 1440, 1484, 1500, 1562, 1570, 1596, 1600, 1650, 1666, 1680, 1718, 1745, 1774, 1800, 1840*, 1850, 1855, 1875, 1894, 1920, 1952, 1968, 1979, 1995, 2000, 2048, 2080, 2094, 2100, 2160, 2164, 2199, 2200, 2250, 2356, 2400, 2485, 2500, 2514, 2519, 2540, 3000, 3600, 4000, 4096, 5000

*AB or ABC output only. NOTE: Resolutions up to 72,000 are available.

For Model H20 Resolutions See Table A on Page 18.

For Model HS35 Resolutions See Table A on Page 23.

For Model HS25 Resolutions See Table A on Page 20.

For Model L15 Resolutions See Table A on Page 31.

For Model HS45 Resolutions See "Cycles per Turn" in Ordering Information.