

22 | HS35 Incremental Optical Encoder

Mechanical Specifications

- Shaft Bore:** 1.00", 0.875", 0.750", 0.625", 0.500". Diameters under 0.875" are supplied with insulating sleeves.
- Allowable Misalignment:** 0.005" T.I.R. on mating shaft 0.75" from shaft end
- Bore Runout:** 0.001" T.I.R maximum
- Starting Torque at 25°C:** Through shaft version (SS) = 7 in-oz (max); Blind shaft version (BS) = 4 in-oz
- Bearings:** 52100 SAE High carbon steel
- Shaft Material:** 416 stainless steel
- Bearing Housing:** Die cast aluminum with iridite finish
- Cover:** Die cast aluminum with iridite finish
- Bearing Life:** 7.5×10^9 revs (50,000 hrs at 2500 RPM)
- Maximum RPM:** 6,000 RPM (see Frequency Response below)
- Moment of Inertia:** 0.019 oz-in-sec²
- Weight:** 18 oz typical

Electrical Specifications

- Code:** Incremental
- Output Format:** 2 channels in quadrature, 1/2 cycle index gated with negative B channel
- Cycles Per Shaft Turn:** 1 to 10,000 (see table A, page 23). For resolutions above 5000 see interpolation options on pages 32 and 33
- Supply Voltage:** 5 to 24 VDC available (see note 5)
- Current Requirements:** 100 mA typical +output load, 250 mA (max)
- Output Device:** (see note 5)
 - 4469: Line Driver, 5 – 15 VDC, $V_{out} = V_{in}$
 - 7272: Line Driver, 5 – 28 VDC, $V_{out} = V_{in}$
 - 7272: Line Driver, 5 – 28 VDC, $V_{out} = 5$ VDC (special feature)
 - 7273: Open Collector, accepts 5 – 28 VDC
- Protection Level:** Reverse, overvoltage and output short circuit (See note 5)
- Frequency Response:** 150 kHz (up to 5000 cpt resolution; 300 KHz above 5000 cpt, also see Note 7)
- Output Terminations:** See Table 1 page 51
- Note:** Consult factory for other electrical options

Environmental Specifications

- Enclosure Rating:** NEMA 4 & 13 (IP65) when ordered with shaft seal (on units with an MS connector) or a cable gland (on units with cable termination)
- Temperature:** Operating, 0° to 70° C; extended temperature testing up to 105° C available (see note 8); Storage, -25° to 90° C unless extended temperature option called out
- Shock:** 50 g's for 11 msec duration
- Vibration:** 5 to 2000 Hz @ 20 g's
- Humidity:** 98% RH without condensation

NOTES & TABLES: All notes and tables referred to in the text can be found on pages 50 and 51.





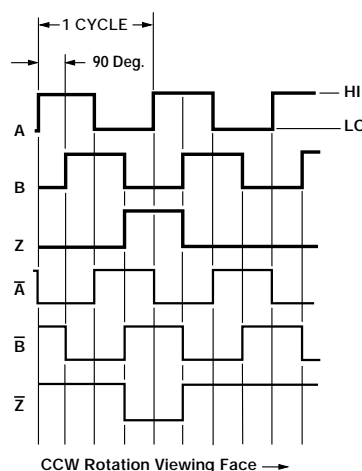

The HS35 combines the rugged, heavy-duty features usually associated with shafted encoders into a hollow shaft style. Its design includes dual bearings and shaft seals for NEMA 4, 13 and IP65 environmental ratings, a rugged metal housing, and a sealed connector or cable gland. The HS35 accommodates shafts up to 1" in diameter. With optional insulating inserts, it can be mounted on smaller diameter shafts. It can be mounted on a through shaft or a blind shaft with a closed cover to maintain its environmental rating. Applications include motor feedback and vector control, printing industries, robotic control, oil service industries, and web process control.

Figure 1 Output Waveform



Certifications

The HS35 Incremental Encoder is available with the following certifications:

-  EN 55011 and EN 61000-6-2
-  CENELEC EEX ia IIC T4
-  U.S. Standards Class I, Group A,B,C & D; Class II Group E, F & G
-  Canadian Standards Class I, Zone 0, Group IIC

See Regulatory Information on pages 47–49 for further certification details.

MS Connector Termination

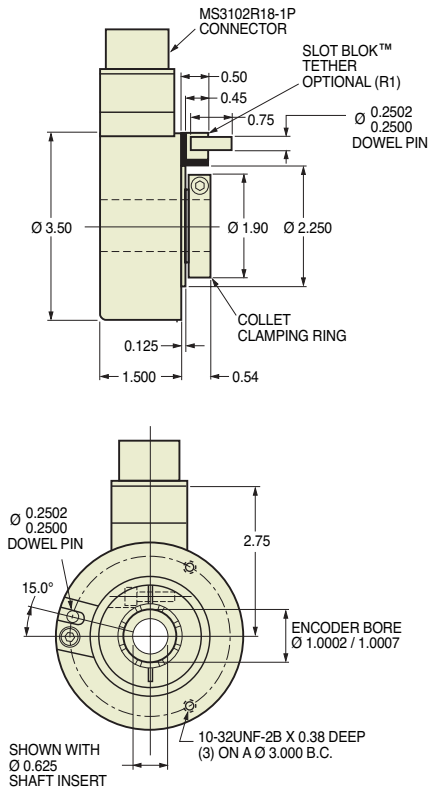

Cable Termination

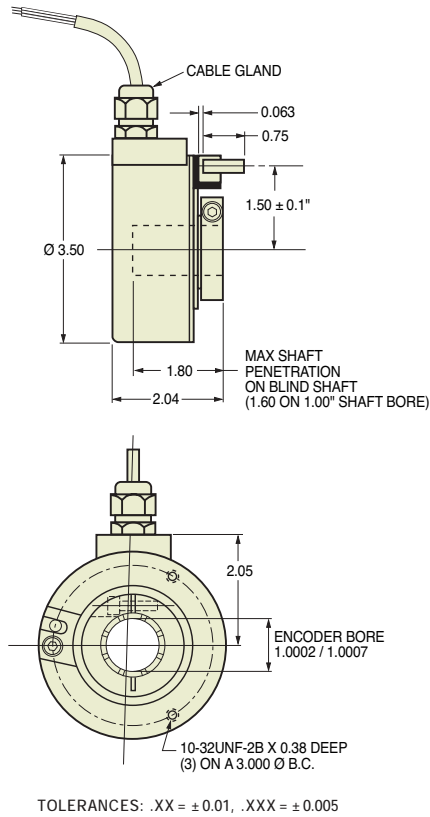

R1 Tether Block and Pin

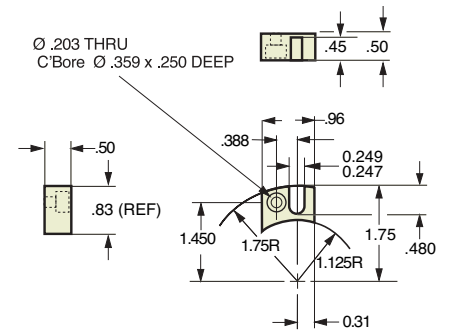

R2 Tether Arm

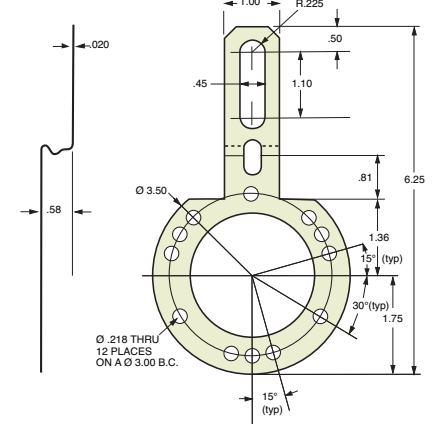

Table A HS35 Disc Resolutions

32 100 250 360 500 512 600 1000 1024 1200 1650 1800 2000 2100 2048 2500 2881 2884 3600 4096 5000

For interpolation please specify the multiplied output (up to 10,000 for the HS35) in the model number, i.e. 10,000-T2. Other resolutions available—consult factory.

HS35 Incremental Ordering Options FOR ASSISTANCE CALL 800-350-2727

Use this diagram, working from left to right to construct your model number (example: HS35F-100- R1-SS-2048-ABZC-7272-SM18). All notes and tables referred to can be found on pages 50-51.

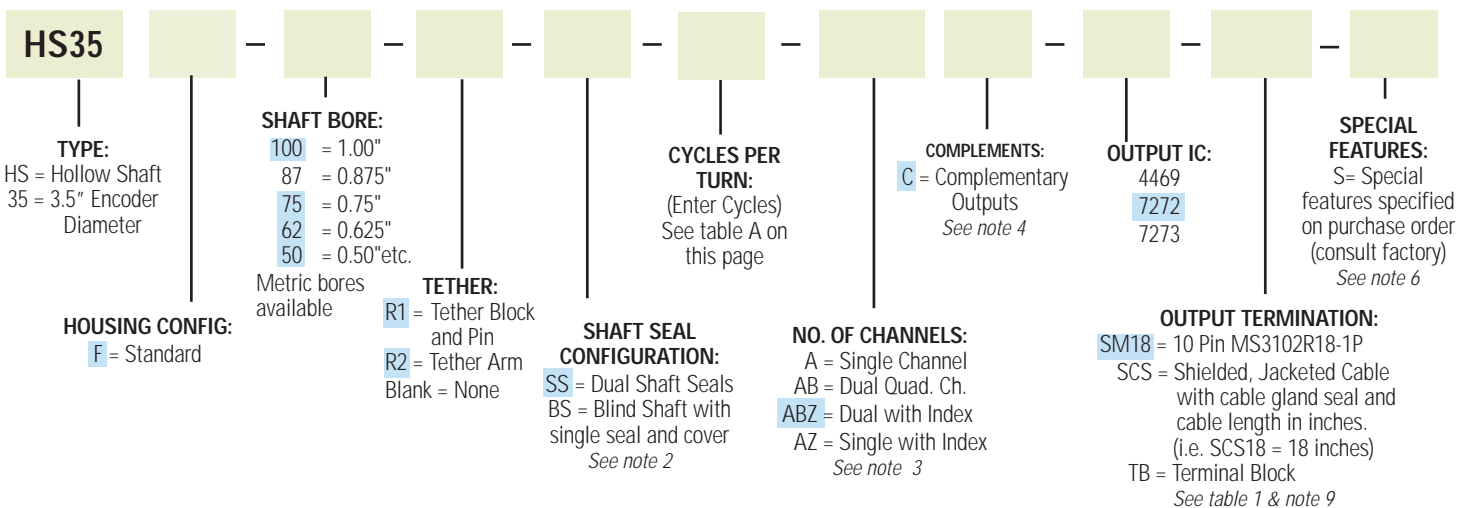

EXPRESS ENCODERS® Items highlighted with are standard Express Encoders and ship in one to three days.

T2 option is available as a standard HS35 Express Encoder. See page 32-33.

1. Mounting is usually done either using the D-style square flange mount, E- or G-style servo mounts, or one of the standard face mounts, F1 for example. Consult factory for additional face mount options.
2. The shaft seal is recommended in virtually all installations. The most common exceptions are applications requiring a very low starting torque or those requiring operation at both high temperature and high speed.
3. Non-standard index widths and multiple indices are available by special order. Consult factory.
4. Complementary outputs are recommended for use with line driver type (source/sink) outputs. When used with differential receivers, this combination provides a high degree of noise immunity.

5. Output IC's

Output IC's are available in either Line Driver (LD) or Open Collector (OC) types. Open Collectors require pull-up resistors and so have higher output impedance. In general it is recommended to use a Line Driver style of output. They can either source or sink current and their lower impedance mean better noise immunity and faster switching times. Our applications specialists would be pleased to discuss your system requirements and the compatibility of your receiving electronics with Line Driver type outputs.

7272

Multi-voltage Line Driver: 100 mA source/sink. Input voltage 5 to 28 VDC standard (Note: $V_{out} = V_{in}$). Available with voltage regulator for 5 to 28 VDC input/TTL output (called out as a special feature)*. This driver is TTL compatible when used with 5 volt supply or with a voltage regulator option. Supply lines are protected against overvoltage to 60 volts and reverse voltage. Outputs are short circuit protected for one minute. Supply current is 120 mA typical (plus load current). This is the recommended replacement for 3904R and 7406R open collector outputs with internal pullup resistors. This is also a direct replacement for any 4469, 88C30, 8830 or 26LS31 line driver

4469

Multi-voltage Line Driver: 100 mA source/sink. Input voltage 5 to 15 VDC standard (Note: $V_{out} = V_{in}$). Available with voltage regulator for 5 to 28 VDC input/5V output (called out as a special feature)*. TTL compatible when used with 5 volt supply or with voltage regulator. Supply lines are protected against overvoltage to 60 volts and reverse voltage. Outputs are short circuit protected for one minute. Supply current is 90 mA typical (plus load current). This is the replacement for 3904R and 7406R outputs for systems operating at 15 volts and below. This is also a direct replacement for any 88C30, 8830, or 26LS31 Line Driver.

* Regulated Output Option:
Limit signal output current to 50 mA per channel on Supply voltages above 15 VDC.
Operation above the stated levels may result in thermal shutdown of the regulator.

7273

Open Collector: Current sink of 80 mA max. Current sourced by external pull-up resistor. Output can be pulled up to voltage other than supply voltage (30 V max). Input voltage 5 to 28 VDC standard. Supply current is 120 mA typical. This replaces prior IC's with designations of 3904, 7406, 3302, 681 and 689.

7406 (R)

Open Collector: Current sink of 40 mA max. Current sourced by external pull-up resistor. When called out as 7406R, pull-ups are internal and sized at approximately 100 ohms/volt and current sink is limited to 30 mA. Output can be pulled up to voltage other than supply voltage (30 V max) when the 7406 is used without internal pull-ups. Voltage regulator can be used to allow supply voltage up to 28 V (called out as a special feature). Supply current is 100 mA typical, 120 mA with internal pull-ups. The 7406R is replaced by the 4469 or the 7272 in system upgrades, or with the 7273 if external pull-ups are used.

3904 (R)

Open Collector: Current sink of 80 mA max. Current sourced by external pull-up resistor. When called out as 3904R, pull-ups are internal and sized at approximately 100 ohms/volt and current sink is limited to 70 mA. Output can be pulled up to voltage other than supply voltage (30 V max) when the 3904 is used without internal pull-ups. Supply Current is 80 mA typical, 100 mA with internal pull-ups. The 3904R is replaced by the 4469 or the 7272 in system upgrades, or with the 7273 if external pull-ups are used.

6. Special -S at the end of the model number is used to define a variety of non-standard features such as special shaft lengths, voltage options, or special testing. Please consult the factory to discuss your special requirements.
7. Higher frequency response may be available. Please consult with the factory.
8. Extended temperature ratings are available in the following ranges: -40 to 70°C, -40 to 85°C, -20 to 105°C and -40 to 105°C depending on the particular model. Extended temperature ranges can affect other performance factors. Consult with factory for more specific information.
9. Mating straight plug receptacles may be ordered from the factory:

For M12 use MS3116F12-10S

For M14 use MS3106F14S-6S

For M14/19 use MS3116F14-19S

For M16 use MS3106F16S-1S

For M18 use MS3106F18-1S

For M20 use MS3106F20-29S

For additional Accessories refer to page 46.

For standard pinouts, refer to the facing page.

Table 1: Incremental Output Terminations

The connector style will determine pinouts. For example, an encoder with ABC channels and an M18 connector uses the table to the right.

M14 CONNECTOR	M16 CONNECTOR	CHANNELS DESIGNATED IN MODEL NO.	
PIN	PIN	ABZ	ABC
E	A	A	A
D	B	B	\overline{B}
C	C	Z	\overline{A}
B	D	+V (SUPPLY VOLTAGE)	
F	E	—	\overline{B}
A	F	0 V (CIRCUIT GROUND)	
	G	CASE GROUND (CG) (except H20)	

M18 CONNECTOR	
PIN	CHANNEL
A	A
B	B
C	Z
D	+V
E	—
F	0V
G	CG
H	\overline{A}
I	\overline{B}
J	\overline{Z}

WIRE COLOR (22AWG)	DA 15P CONNECTOR	CHANNELS DESIGNATED IN MODEL NO.		
		ABZ	ABC	ABZC
YEL	13	A	A	A
BLUE	14	B	B	B
ORN	15	Z	—	Z
W-Yel	10	—	\overline{A}	\overline{A}
W-Blu	11	—	\overline{B}	\overline{B}
W-Orn	12	—	—	\overline{Z}
RED	6	+V (SUPPLY VOLTAGE)		
BLK	1	0 V (CIRCUIT GROUND)		
GRN	9	CASE GROUND (CG) (except H20)		
WHITE		SHIELD DRAIN (Shielded Cable Only)		

M12 CONNECTOR	
PIN	CHANNEL
A	A
B	B
C	Z
D	+V
E	—
F	0V
G	CG
H	\overline{A}
J	\overline{B}
K	\overline{Z}

Table 2: Disc Resolutions for Incremental Encoder Models H25, H38, H40, L 25, E25

Resolutions highlighted with are available as standard **Model H25 EXPRESS ENCODERS**® that ship in one to three days.

1, 2, 3, 5, 6, 7, 8, 10, 13, 16, 20, 24, 25, 26, 30, 32, 33, 34, 36, 37, 40, 45, 48, 50, 51, 56*, 60, 64, 66, 72, 75, 80, 86, 88, 90, 100, 102, 120, 122, 125, 127, 128, 132, 144, 148, 150, 158, 160, 175, 176, 180, 187, 192, 200, 202, 204*, 217, 220, 240, 250, 254, 255, 256, 264*, 274, 280, 283, 288, 292, 300, 312, 320, 321, 325, 360, 366, 372, 375, 377, 380, 381, 384, 385, 393, 400, 430, 432, 450, 462, 480, 490, 500, 502, 508, 512, 522, 530, 550, 560*, 576, 598, 600, 604, 625, 628, 635, 638, 640, 660, 672, 676, 680, 687, 690, 700, 720, 725, 735, 740, 744, 748, 750, 762, 768, 780, 785, 800, 812, 825, 850, 864, 878, 888, 900, 912, 914, 938, 942, 955, 960, 1000, 1016, 1024, 1030, 1035, 1036, 1040, 1054, 1056, 1074, 1076, 1080, 1088, 1100, 1101, 1125, 1136, 1200, 1237, 1250, 1257, 1270, 1280, 1300, 1314, 1332, 1333, 1390, 1400, 1414, 1427, 1440, 1484, 1500, 1562, 1570, 1596, 1600, 1650, 1666, 1680, 1718, 1745, 1774, 1800, 1840*, 1850, 1855, 1875, 1894, 1920, 1952, 1968, 1979, 1995, 2000, 2048, 2080, 2094, 2100, 2160, 2164, 2199, 2200, 2250, 2356, 2400, 2485, 2500, 2514, 2519, 2540, 3000, 3600, 4000, 4096, 5000

*AB or ABC output only. NOTE: Resolutions up to 72,000 are available.

For Model H20 Resolutions See Table A on Page 18.

For Model HS35 Resolutions See Table A on Page 23.

For Model HS25 Resolutions See Table A on Page 20.

For Model L15 Resolutions See Table A on Page 31.

For Model HS45 Resolutions See "Cycles per Turn" in Ordering Information.