

ES25

Environmentally Sealed Incremental Encoder



The **ES25** is a rugged incremental encoder that is environmentally sealed through the use of a magnetic shaft coupling connection. This connection allows the encoder to be completely enclosed and sealed against water ingress. It is rated to IP67 and can operate while fully immersed in one meter of water for up to 30 minutes. The magnetic coupling isolates the encoder from external equipment, protecting it from high shock, vibration and environmental debris. Since the ES25 is not physically coupled to external equipment, the problem of shaft misalignment is eliminated, meaning no more broken couplings! The ES25 is ideal for applications with heavy wash-downs, temporary water immersions, and excessive environmental debris. It combines the high accuracy, repeatability and robustness needed for use in harsh environments and can help reduce costly downtime of your system.

Specifications

Mechanical

Mating Shaft Diameter: 1/4" and metric versions
Magnetic Coupling Cover: Engineered plastic
Starting Torque: 0.5 oz-in max
Enclosure: Aluminum (sealed aluminum castings)
Maximum RPM: 5000 RPM
Moment of Inertia: 62.3×10^{-4} oz-in-sec²
Maximum Acceleration: 24,000 rad/s/s
Torsional flexibility: 0.37 deg/oz-in
Kinematic Error: 3 arc-min_{RMS}
Weight: 18 oz

Electrical

Supply Voltage: 5 to 28 VDC available
Voltage/ Output:
 28V/V: Line Driver, 5-28 VDC in, V out = V in
 28V/5: Line Drive, 5-28 VDC in, V out = 5 VDC
 28V/OC: Open Collector, 5-28 VDC in, OC out
Current Requirements: 100 mA typical + output load, 250 mA (max)
Protection Level: reverse, overvoltage and output short circuit
Code: Incremental
Output Format: 2 Channels in quadrature, with 1/2 cycle index gated with negative B channel
Cycles per Shaft Turn: 1 to 2,048 (See Table 1)
Frequency Response: 100 KHz
Output Terminations: (See Table 2)

Environmental

Temperature: Operating, 0° to 70°C; storage (non-operating), -25° to 90°C. Consult factory for extended temperature ratings.
Shock: 25 g's for 11 msec duration
Vibration: 5 to 2000 Hz @ 10 g's
Humidity: 100% RH with condensation
Enclosure Rating: IP67 / IP68 (Consult factory for IP68 applications)

ES25 Environmentally Sealed Incremental Encoder Ordering Options *For assistance, call 800-350-2727*

Use this diagram, working from left to right, to construct your model number.

Example: **ES25D-37-500-ABZC-28V/V-SM18-S** (-S: special shaft, diameter/ length, output level or termination)

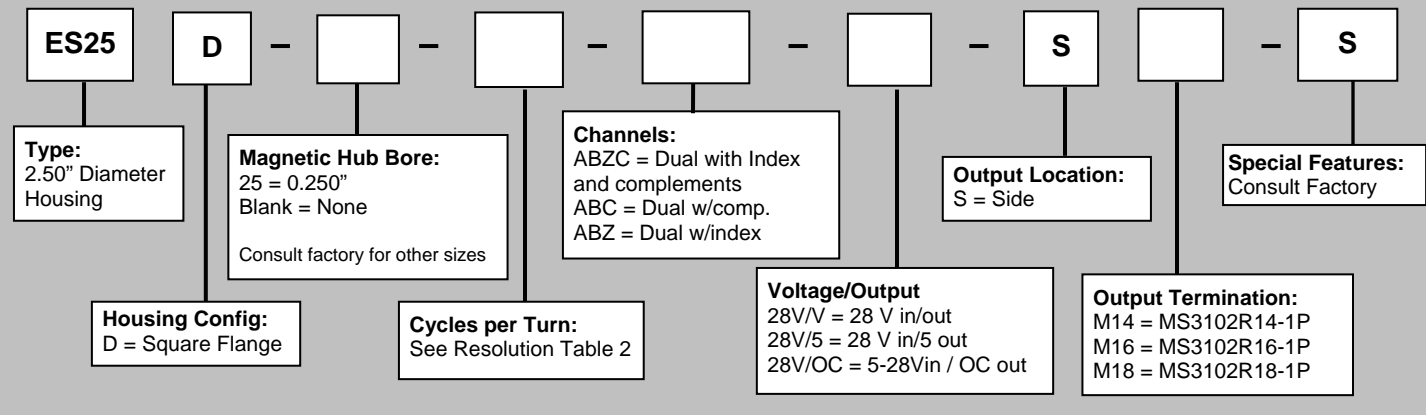

Table 1: Resolutions

1	2	3	5	6	8	10	11	13	16	20	24	25	26	30	32	33
34	36	37	40	45	48	50	51	60	64	66	72	75	80	86	88	90
100	102	120	122	125	127	128	132	144	148	150	158	160	175	176	180	187
192	200	202	217	220	240	250	254	255	256	274	280	283	288	292	300	312
320	321	325	360	366	372	375	377	380	381	384	385	393	400	430	432	450
462	480	490	500	502	508	512	522	530	550	576	598	600	604	625	628	635
638	640	660	687	690	700	720	725	735	740	744	748	750	762	768	780	785
800	812	825	850	864	878	888	900	912	914	938	942	955	960	1000	1016	1024
1030	1035	1036	1040	1054	1056	1074	1076	1080	1088	1100	1101	1125	1136	1200	1237	1250
1257	1270	1280	1300	1314	1332	1333	1390	1400	1414	1427	1440	1484	1500	1562	1570	1596
1600	1650	1666	1718	1745	1774	1800	1850	1855	1875	1894	1920	1952	1968	1979	1995	2000
2048																

Table 2: Output Terminations

M18 Connector	
PIN	Channel
A	A
B	B
C	Z
D	+V
E	---
F	0V
G	CG
H	A/
I	B/
J	Z/

Output Waveform

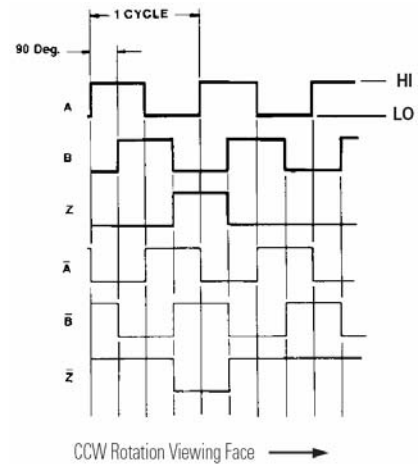

ES25 Dimensions

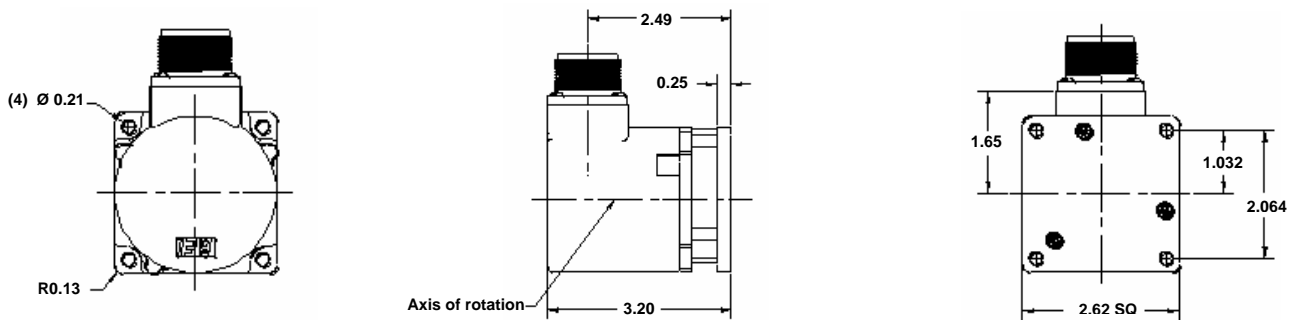

Magnetic Hub

Magnetic Hub Bore .250"
 BEI Part No. 924-38540-250
 (supplied with encoder)

Consult factory for other bore sizes

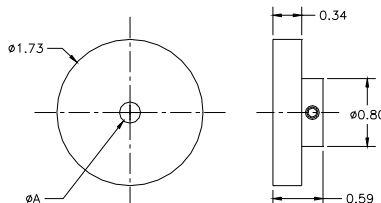

These commodities, technology or software if exported from the United States must be in accordance with the Bureau of Industry, and Security, Export Administration regulations. Diversion contrary to U.S law is prohibited.

